



ABS SUBMERSIBLE PROPELLER PUMPS VUPX

- High operational reliability and long operating life
- Well known modular construction
- High quality materials
- Newly designed hydraulics with high efficiencies
- Avoidance of harmful vortices by anti-vortex-system

Applications

The ABS submersible propeller pumps of the VUPX series are ideal for applications where large volumes of waste or process water have to be pumped up to heads of 12 m.

They are compact and can be installed vertically in a space saving manner. They are ideal for storm water protection, for irrigation and dewatering, for cooling and process water and for a multitude of other applications.

Technology

By the use of an economical building block principle, we are able to select the best combination of hydraulic and motor with reference to output, speed, voltage and frequency in order to suit the particular application.

The choice of between three and four propeller blades, and a motor range from 4.5 to 650 kW enable us to make a choice which fulfils both economical and technical criteria.

ABS propeller pump with motor and hydraulic section designed on the building block principle

Water tight motor enclosure to IP 68; stator wound and impregnated according to class H with thermal sensors. Rotor and shaft dynamically balanced



Ball bearings, lubricated-for-life support the shaft at upper and lower ends

Axial hydraulics with diffusers located at the suction and discharge sides. Replaceable wear ring of stainless steel. Material wear ring G-X7CrNiMo12-1 (=1.4008)

All motors can also be supplied to European explosion proof standards

Coupling device with conical centering unit secured against rotation and water tight

Propeller with adjustable blades of stainless steel. Material: G-X40CrNi27-4 (=1.4340). Propeller blades

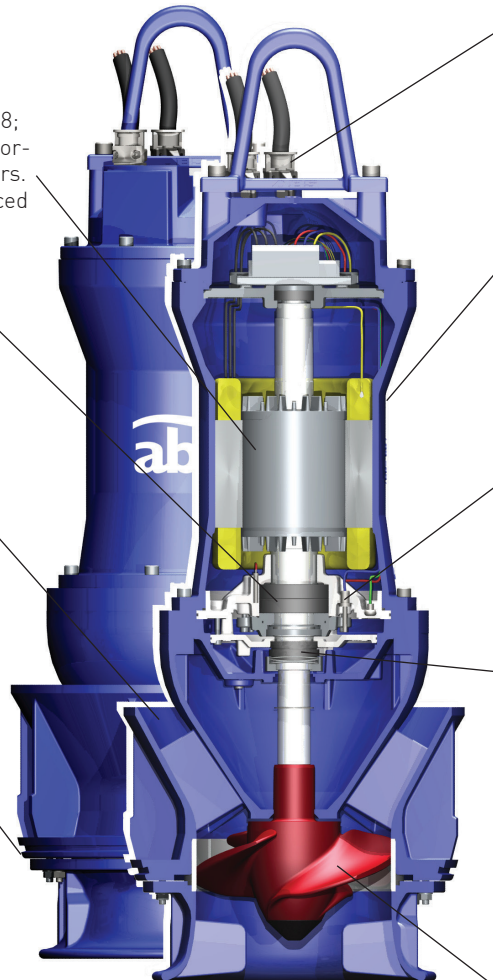

Water tight enclosed connection chamber IP 68. Cable inlet with strain relief anti-kink device and double seal



Optimum motor cooling by directing the medium being pumped over the motor

For optimum security ABS provides a system of monitoring devices. The pumps are permanently monitored to ensure that faults or wear are reported in plenty of time. This means that major damage to these high quality submersible pumps can be avoided by timely inspection

High quality mechanical seal with solid silicon carbide rotating seats ensure reliable shaft sealing



3-Blade propeller in the new skew design (for VUPX 0403/0503/0603). Material: GGG-NiCr20-2 (=0.7660). The blades have been designed with the aid of a computer programme and incorporates the latest flow design principle

All pumps are routinely tested during production to achieve the performance standard of ISO 9906 Cl.2. Performance tests to ISO 9906 Cl.1 are also available

Installation

Suitable for installation in steel or concrete riser pipes for economical and simple operation of the units. The centering of the pump and sealing between pump and pipe line is carried out automatically by means of a conical coupling ring.

No additional installation work required.

Maintenance

If maintenance is required you simply lift up the pump as a unit, without any need for disassembly, out of the flooded or dry pump sump.

You can then carry out the maintenance work where ever is most convenient.

Technical Specifications

Nominal pipe diameter:	600 - 1400 mm
Power range:	4.5 - 650 kW
Pole number:	4 - 12

Performance Curves

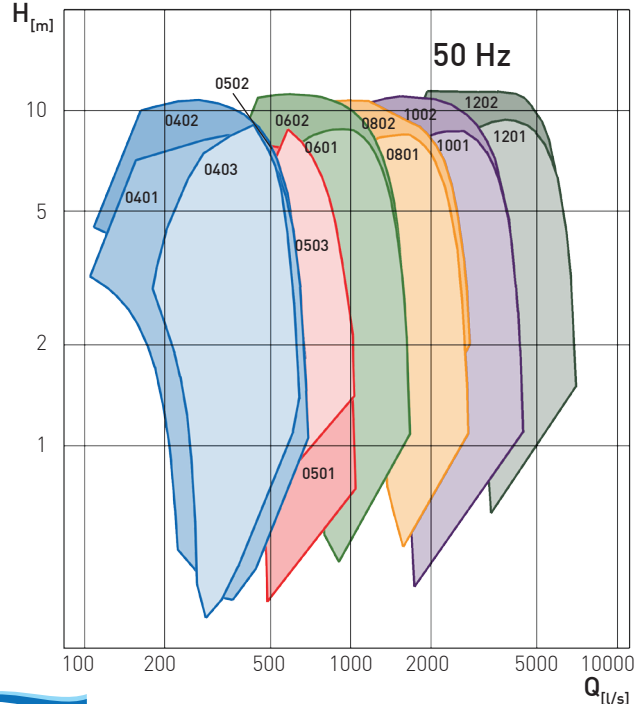

Australia
Tel: +61 7 3710 5200
Fax: +61 7 3279 1828
Email: info-au@absgroup.com
www.absgroupau.com

China
Tel: +86 21 6888 2900
Fax: +86 21 5882 6708
Email: info-ap@absgroup.com
www.absgroup.cn

Malaysia
Tel: +60 3 5631 3118
Fax: +60 3 5631 6122
Email: info-ap@absgroup.com
www.absgroup.com

Singapore
Tel: +65 6463 3933
Fax: +65 6462 2122
Email: info-ap@absgroup.com
www.absgroup.com