

# ABS venturi jet aerator

Jet aerator with single or twin diffuser pipes, for fixed or portable installation, coupled to a Premium Efficiency pump from the XFP range.

## Applications

For the combined aeration and mixing of wastewater in small and medium sized tanks. Also for the cleaning of storm water tanks and for use in balancing tanks where a combination of aeration and mixing reduces septicity and minimizes odours.

## Features

- Stand-alone, self-aspirating system, with the option of fixed installation with guide rail and pedestal, or portable installation with stand. The portable option is especially suitable for emergency or intermittent aeration tasks and allows for variable positioning in the tank.
- Uses standard XFP pump featuring continuously rated Premium Efficiency motor, double mechanical seals, and temperature and seal monitoring.
- Blockage-free hydraulic design with Contrablock impeller.
- Lower noise levels and reduced spray compared to surface systems.
- Maximum allowable temperature of the medium for continuous operation is 40 °C.

## Venturi injection principle

The ABS venturi jet aerator is based on the injection principle that produces an effective air-water mix which results in optimum aeration and suspension of solids. The velocity of the primary flow of liquid from the pump is accelerated when pumped through the smaller nozzle inlet, lowering the internal pressure which draws in the secondary flow of air through the air inlet pipe. The liquid and air flows are then mixed in the turbulence of the diffuser pipe and ejected as a jet of fine air bubbles into the tank.

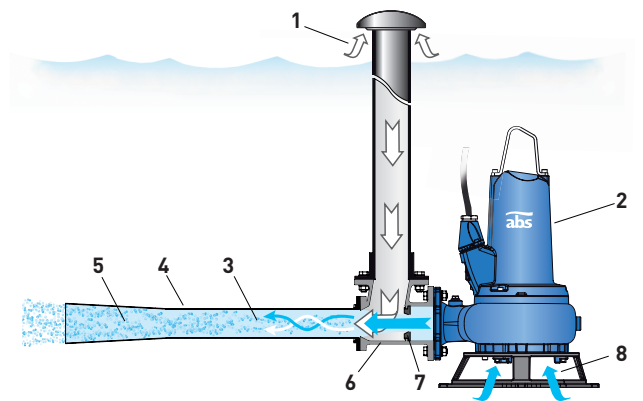

- |                         |                            |
|-------------------------|----------------------------|
| 1. Air inflow           | 5. Mixed flow              |
| 2. XFP submersible pump | 6. Venturi chamber housing |
| 3. Mixing zone          | 7. Nozzle inlet            |
| 4. Diffuser pipe        | 8. Liquid inflow           |



## Motor

Premium Efficiency IE3, three-phase, squirrel-cage motor; 400 V; 50 Hz; 4-pole (1450 r/min) and 6-pole (980 r/min).  
 Protection type: IP 68  
 Stator insulation: Class H.  
 Start-up: 1.3 - 2.9 kW = direct on line (DOL).  
 4.0 - 11.0 kW = star-delta (YΔ).  
 Cooling: 100C - 150E self-cooling,  
 150G & 200G version with closed cooling system.  
 Service factor: 1.3

## Materials

Aerator	Material
Diffuser pipe	Stainless steel 1.4301 (AISI 304)
Venturi chamber housing	Cast iron EN-GJL-200
Pump	Material
Motor housing	Cast iron EN-GJL-250
Motor shaft	Stainless steel 1.4021 (AISI 420)
Volute	Cast iron EN-GJL-250
Impeller	Cast iron EN-GJL-250
Bottom plate	Cast iron EN-GJL-250
Lifting hoop	Stainless steel 1.4401 (AISI 316)
Fasteners	Stainless steel 1.4401 (AISI 316)

## Notes:

1. Stand and pedestal supplied as accessories.
2. Air inflow pipe and fittings, elbows and flanges supplied by customer.

## Technical Data

XFP Pump	Motor	Impeller size	Pump discharge DN	Aerator inlet DN	Nozzle $\varnothing$ mm	Water flow m <sup>3</sup> /h	Motor power* (kW)		Rated current A	Cable size	Weight** (pump) kg
							P <sub>1</sub>	P <sub>2</sub>			
<b>100C-CB1</b>	PE13/6	1	100	100	55	50	1.6	1.3	3.6	7G1.5	105
	PE22/4	4	100	100	55	70	2.5	2.2	4.6	7G1.5	107
	PE29/4	2	100	100	55	100	3.0	6.4	6.4	7G1.5	109
<b>100E-CB1</b>	PE40/4	5	100	100	55	140	4.4	4.0	8.4	10G1.5	159
<b>150E-CB1</b>	PE60/4	4	150	150	80	190	6.7	6.0	13.6	10G1.5	186
	PE90/4	1	150	150	80	240	10.0	9.0	18.1	10G1.5	198
<b>150G-CB1</b>	PE160/4	3	150	150	80	315	17.4	16.0	33.1	10G2.5	347
<b>200G-CB1</b> <sup>1)</sup>	PE185/4	2	200	150	80	500	20.0	18.5	36.9	10G2.5	375

\* P1 = power at mains. P2 = power at motor shaft.

\*\* Aerator weight: DN 100 = 20 kg, DN 150 = 40 kg (does not include air inlet pipe or fittings).

Portable stand: 100C = 9.5 kg, 100 & 150E = 10.5 kg, 150 & 200G = 17.5 kg.

<sup>1)</sup> XFP 200G requires twin aerators. DN 150 T-piece, 2 x DN 150 elbows and DN 200 / DN 150 adaptor flange required for connection to pump discharge.

## Aerator selection / Tank dimensions (m)

XFP pump	Motor	Impeller size	Wastewater tank (sample size)			Storm water tank (sample size)		
			Rectangular	Square	Circular	Rectangular (outflow at one side)	Rectangular (central channel)	Circular (central outflow)
<b>100C-CB1</b>	PE13/6	1	6.0 X 4.0	4.9	$\varnothing$ 5.5	-	-	-
	PE22/4	4	7.2 X 4.8	5.9	$\varnothing$ 6.6	-	-	-
	PE29/4	2	8.0 X 5.3	6.5	$\varnothing$ 7.4	8.0 X 6.0	8.0 X 5.0	$\varnothing$ 5.5
<b>100E-CB1</b>	PE40/4	5	9.5 X 6.3	7.8	$\varnothing$ 8.8	10.0 X 8.0	10.0 X 6.5	$\varnothing$ 6.5
<b>150E-CB1</b>	PE60/4	4	12.0 X 8.0	9.8	$\varnothing$ 11.1	18.0 X 10.0	15.0 X 8.0	$\varnothing$ 8.0
	PE90/4	1	15.0 X 10.0	12.2	$\varnothing$ 13.8	22.0 X 12.0	20.0 X 10.0	$\varnothing$ 13.0
<b>150G-CB1</b>	PE160/4	3	17.5 X 11.5	14.2	$\varnothing$ 16.0	24.0 X 13.0	22.0 X 10.0	$\varnothing$ 14.0
<b>200G-CB1</b>	PE185/4	2	21.0 X 13.0	16.4	$\varnothing$ 18.0	27.0 X 14.0	24.0 X 10.0	-

## Air flow performance

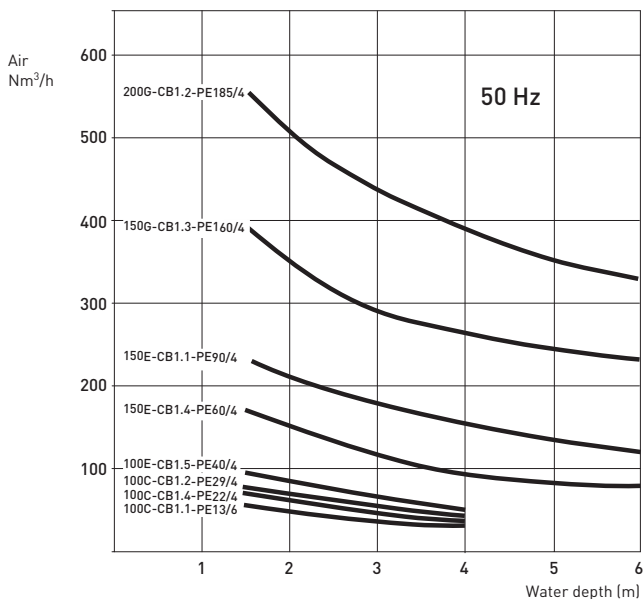

## Oxygen transfer performance

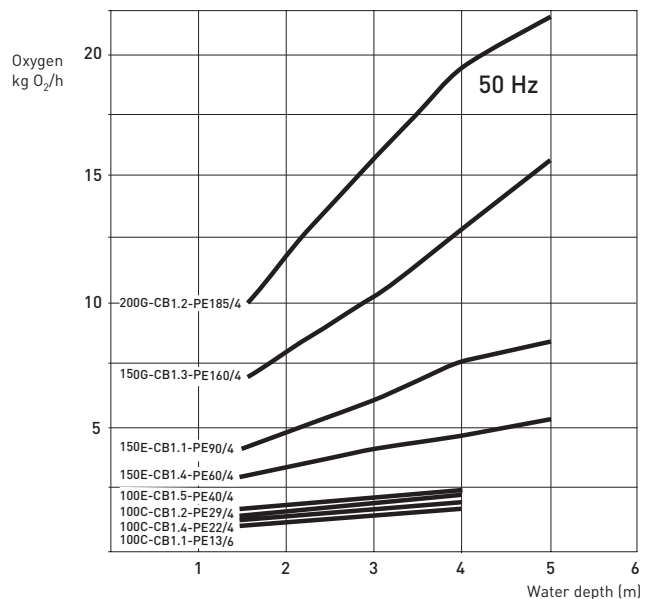

Oxygen transfer data measured as per "Measurement of Oxygen Transfer in Clean Water" ASCE Standard 2-06, 2006.

## Dimensions (mm)

### Transportable installation

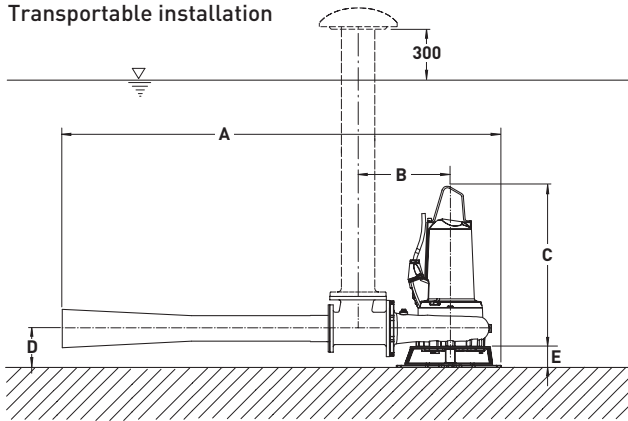

Note: in some cases the support stand may need to be weighted to the tank base to prevent lateral movement of the unit.

	100C	100E	150E		150G	200G*
			PE60/4	PE90/4		
<b>A</b>	1596	1636	2239	2239	2319	2384*
<b>B</b>	390	405	471	471	496	543*
<b>C</b>	686	728	749	819	1261	1348
<b>D</b>	193	179	198	198	300	320
<b>E</b>	105	105	105	105	200	200

\* Twin aerators as standard and only.

Required: DN 150 T-piece, 2 x DN 150 elbows and FN 200 / DN 150 adaptor flange for connecting to pump discharge (not included in dimension; supplied by customer).

### Installation with straight pedestal

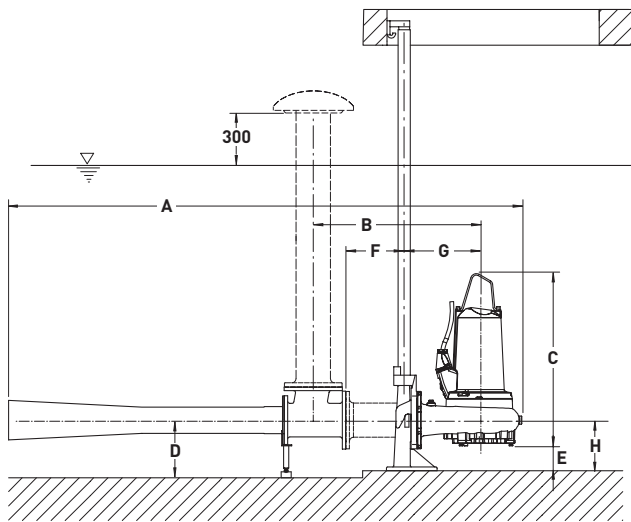

	100C	100E	150E		150G	200G
			PE60/4	PE90/4		
<b>A</b>	1594+F	1627+F	2251+F	2251+F	2316+F	2505+F
<b>B</b>	442+F	655+F	531+F	531+F	556+F	995+F
<b>C</b>	716	762	783	853	1297	1348
<b>D</b>	289	289	286	286	286	286
<b>E</b>	82	92	123	123	114	119
<b>F</b>	**	**	**	**	**	**
<b>G</b>	318	333	372	372	397	546
<b>H</b>	200	200	250	250	250	240

\*\* Variable dimension (supplied, and dimensions specified, by customer)

Required: DN 100 or DN 150 flange for XFP 100C - 150G

DN 150 T-piece, 2 x DN 150 elbows and DN 200 / DN 150 adaptor flange for XFP 200G.

### Installation with 90° (duckfoot) pedestal

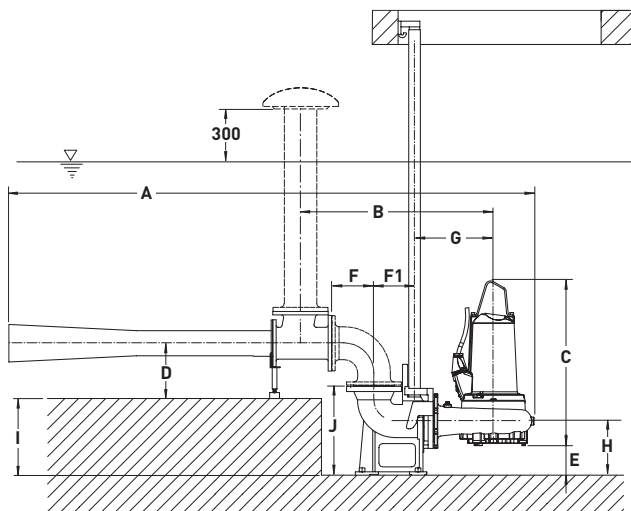

	100C	100E	150E		150G	200G
			PE60/4	PE90/4		
<b>A</b>	1816+F	1846+F	2497+F	2497+F	2562+F	2788+F
<b>B</b>	661+F	676+F	777+F	777+F	802+F	988+F
<b>C</b>	716	762	783	853	1297	1348
<b>D</b>	289	289	286	286	286	286
<b>E</b>	107	117	153	153	144	158
<b>F</b>	**	**	**	**	**	**
<b>F1</b>	180	180	210	210	210	297
<b>G</b>	357	372	408	408	433	533
<b>H</b>	225	225	280	280	280	325
<b>I</b>	262	262	397	397	397	524
<b>J</b>	371	371	463	463	463	550

\*\* Variable dimension (supplied, and dimensions specified, by customer)

Required: DN 100 or DN 150 elbow for XFP 100C - 150G

DN 150 T-piece, 2 x DN 150 elbows and DN 200 / DN 150 adaptor elbow for XFP 200G.

Note: further and more detailed dimension drawings for all installation types are available on the IEM-EPM cd or by request.

## Accessories

	Description	Size	XFP	Part no.	
<b>Fixed installation - wet well with ABS Automatic Coupling System</b>	<b>Pedestal (kit)*</b> cast iron EN-GJL-250 90° cast bend (single guide rail) - DIN flange connection	DN 100	100C & 100E	62320652	
		DN 150	150E & 150G	62320655	
		DN 200	200G	DPT91211A	
	<b>Pedestal (components)*</b> cast iron EN-GJL-250 straight (single guide rail) - DIN flange connection	DN 100	100C & 100E	Gasket	14020018
				Base	32560611
				Bracket	41420520
				Seal	43070518
				Guide piece	31450510
		DN 150	150E & 150G	Gasket	14020020
				Base	32560620
				Bracket	31420535
				Seal	43070519
	DN 200	200G		Guide piece	31450510
	<b>Pedestal bracket fasteners</b> single guide rail version (galvanised steel)		100C & 100E 150E & 150G 200G		62610633
					62610635
				62610883	
single guide rail version (stainless steel)			100C & 100E 150E & 150G 200G		62610637
					62610639
					62610862
<b>Pedestal base anchor bolts</b> single and twin guide rail (galvanised steel)		100C & 100E 150E & 150G 200G		62610775	
				62610784	
				62610785	
<b>Chain Kit</b> (galvanized steel) including shackle	3 m	100C - 200G		61265065	
	4 m			61265093	
	6 m			61265069	
	7 m			61265096	
<b>Chain Kit</b> (stainless steel) including shackle	3 m	100C - 200G		61265081	
	4 m			61265099	
	6 m			61265085	
	7 m			61265102	
<b>Transportable</b>	<b>Ground Support Stand</b>		100C	61355016	
			100E	61355018	
			150E	61355019	
			150G & 200G	61355025	
<b>General</b>	<b>Cathodic Protection</b> (zinc anodes)		100C - 200G	13905000	

\*Guide rail not included