

# THERMAL CLEANING OF METAL PARTS & TOOLS



Systems & Services for the Plastics, Fiber and Nonwovens Industries



Clean, safe & fast ■ German Art of Engineering since 1969

Gentle & green

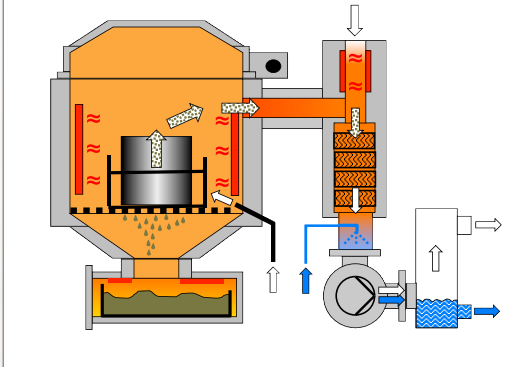

Cleaning time: 8-26 h



**SCHWING**

VACUCLEAN gently removes organic contamination from heat resistant metal parts by melting it off and thermal decomposition under vacuum.

### ADVANTAGES

- Especially gentle cleaning of temperature sensitive parts and tools
- Only electricity and water required
- Catalytic converter for off-gas cleaning

Especially recommended for:

- Spinnerets, melt-blown and spunbond dies
- Filter bundles, leaf disks
- Blown film die heads
- Extruder screws

Fast & flexible

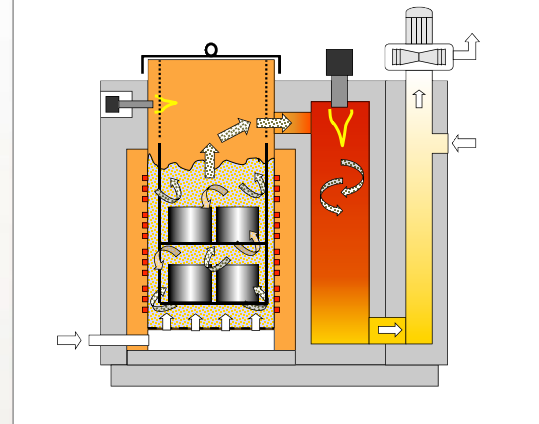

Cleaning time: 1-2 h



**SCHWING**

INNOVACLEAN removes all organic contamination (including halogenated polymers) from heat resistant metal parts by thermal decomposition in a fluidized bed.

### ADVANTAGES

- Very short cleaning times
- Suitable for all polymers (incl. PVC, PTFE, PEEK)
- Highest flexibility

Especially recommended for:

- Spinnerets, assembled spin packs
- Breaker plates
- Special profile dies
- Hot runners

## SYSTEM MAXICLEAN

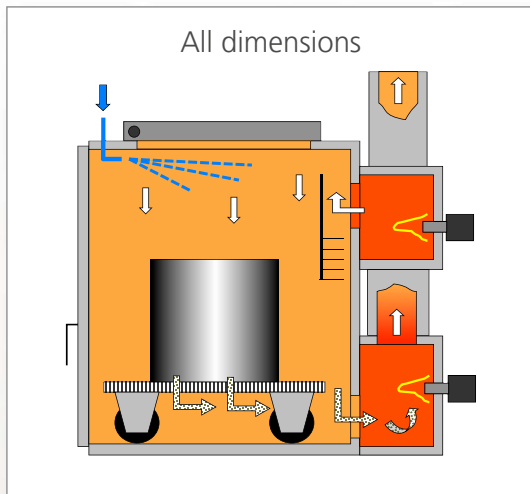

Cleaning time: 4-8 h



SCHWING

MAXICLEAN is a gas-heated thermal cleaning system. It removes all organic contamination from large metal parts and tools by thermal oxidation.

### ADVANTAGES

- For large parts and machine tools
- Applicable for large amount of polymers
- Suitable for most polymers

Especially recommended for:

- Filter bundles
- Extruder screws
- Large extrusion and pelletizing dies
- Large hot runners

## SYSTEM COMPACTCLEAN

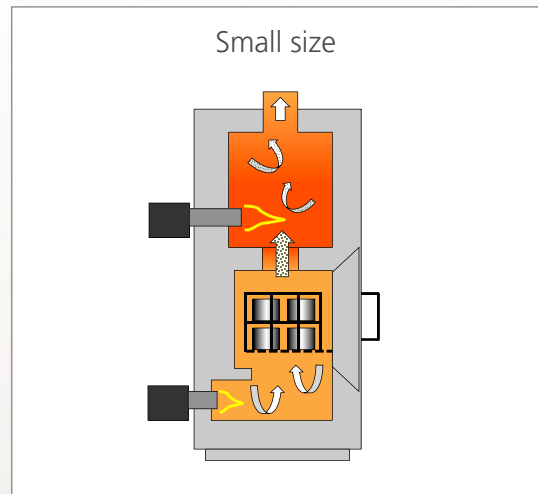

Cleaning time: 3-5 h



SCHWING

COMPACTCLEAN is a small gas heated thermal cleaning system, which removes organic contamination via thermal oxidation. It can be integrated easily into a workshop.

### ADVANTAGES

- Low investment
- Suitable for most polymers
- Small footprint

Especially recommended for:

- Non-return valves
- Breaker plates
- Hot runners
- Needle valves, nozzles

# OUR EXPERTISE – YOUR BENEFITS

## TYPICAL COMPONENTS

- Injection moulding:
- Screws
  - Nozzles
  - Static mixers
  - Needle valves
  - Non-return valves
  - Hot runners
- Extrusion:
- Screws
  - Screw elements
  - Breaker plates
  - Screen changers
  - Filter, Filter plates
  - Profile dies
  - Blown film die heads
- Fiber / Nonwovens:
- Spin packs
  - Spinnerets
  - Spinning pumps
  - Spinning beams
  - Filter bundles, candles

## FOR ALL POLYMERS

- Polyolefins: PE, HDPE, PP, PB, EVA, EVOH
- Polyesters: PET, PBT, PC, PTT, PEN
- Polyamides: PA6, PA6.6, PA12, PPA
- Halogenated Polymers: PVC, PTFE, PVDF
- Polyacrylates: PAN, PBA, PMA, PMMA
- Polystyrenes: PS, ABS, SB, SBS, SAN
- Polysulfides: PPS, PSU, PES, PPSU
- Biopolymers: PLA, PEA, PVAL, PPOX
- Polyetherketones: PAE, PEK, PEEK
- Polyimides: PI, PBI, PEI, PBO, PMI
- Polyurethanes: PUR, TPA, TPO, TPU
- Special Polymers: LCP, POM, BR, NBR
- Your specific polymer: ...

## PERFECTLY CLEAN

- Removal of all polymers
- Free of all polymers & carbon residues
- No damage to parts and tools

## FLEXIBLE SOLUTIONS

- All thermal cleaning methods
- Systems for assembled, disassembled and complex parts and tools
- All sizes and geometries of parts

## INTELLIGENT & SAFE

- Easy and safe operation
- Intelligent control systems
- Automated process management

## ENVIRONMENTALLY FRIENDLY

- Integrated or separate off-gas cleaning
- No polluted water
- Minimized energy consumption

## SERVICE & SUPPORT

- Process consulting and planning
- Commissioning and training
- Technical support

# ACCESSORIES

In addition to its Thermal Cleaning Systems, SCHWING offers optionally a variety of accessories and post treatment systems:



Loading baskets, tables and racks



Chimney elements



Thermal afterburning systems



Ultra sonic & rinsing units

Shot blasting systems



Quality inspection systems

# CLEANING SERVICES



Working from their manufacturing headquarter in Germany, SCHWING designs, engineers, manufactures and markets the most advanced Thermal Cleaning Systems since 1969. Valuable experience resulting in industrial leadership and excellent processes with perfect results for the plastics and fiber industry.

For more than 20 years, the SCHWING Group has provided high quality contract cleaning services from different locations around the world.

More than 250,000 parts are cleaned for hundreds of customers every year. Having this experience and know-how provides strong application support for customers.

Depending on the specific requirements or applications, different Thermal Cleaning Systems are available to remove organic contamination.

The complete range of equipment can handle component weights with more than 5,000 kgs (for example a blown film die head) with lengths up to 6 meters (e.g. nonwoven dies and screws).



In order to obtain completely clean parts, special and carefully selected post treatments have been devised especially for complex parts like spinnerets, spin packs and hot runners.

The cleaning results are always checked and documented by precise process control, strict quality procedures and inspection techniques.

SCHWING has the complete know-how and total experience for all procedures required in thermal cleaning. Take this experience for all of your sophisticated cleaning tasks.



SCHWING Fluid Technik GmbH

Oderstrasse 7  
47506 Neukirchen-Vluyn  
Germany

Phone: +49 2845 930-0

E-mail: [info@schwing-tech.com](mailto:info@schwing-tech.com)  
[www.thermal-cleaning.com](http://www.thermal-cleaning.com)