



HMX-FAAC provides cooling without compromise for Jindal Polyfilms

Background

Jindal Poly Films Limited (JPFL) is a part of the B. C. Jindal group, a 58-year old industrial group with a leadership position in a wide range of products. The group is involved in diverse activities including the manufacturing of polyester films, polypropylene films, steel pipes, and photographic products.

JPFL's fully automated state-of-the-art plant at Nasik, India, is the world's largest single location plant for the manufacturing of BOPET and BOPP films.

Challenges

All the plant activities of the Nasik plant are managed from 2 operation control centers: a Dornier control room, and a winding and instrumentation control room. Both of these centers have critical temperature and RH requirements – i.e., at all times the temperature needs to be below 28°C and the RH should be below 70%.

Based on the cooling load (TR) requirement, normal air conditioners would incur a very large operating cost, as the temperature in summer in Nasik can soar up to 42°C.

Solution

The management of JPFL turned to HMX for an energy-efficient solution.

Considering their requirement, we proposed two HMX-FAAC units, one for the Dornier control room (35000 CFM) and one for the winding and instrumentation control room (7000 CFM). The HMX-FAAC is a revolutionary product that combines indirect direct evaporative cooling and refrigerated air-conditioning. The switch over between modes is automated based on the inputs received from the temperature and RH sensors. It is designed to maintain desired conditions in all seasons and is ideal for applications where maintaining both temperature and RH are critical.

The tables below demonstrate the excellent performance of the HMX system in various modes in different ambient conditions:

Sr. No.	Unit details	Date and time	Ambient	Room
1.	Dornier panel room	22.04.2015	DBT (°C)	DBT (°C)
	HMx-FAAC 35K	12.30 pm	38.00	25.00
		02.30 pm	39.00	26.00
2.	Winding and Instrumentation panel room	22.04.2015	DBT (°C)	DBT (°C)
	HMx-FAAC 7K	12.30 pm	38.00	26.00
		02.30 pm	39.00	26.00

Temperature readings taken in summer when the unit was running in 100% fresh air, i.e., indirect direct evaporative cooling mode

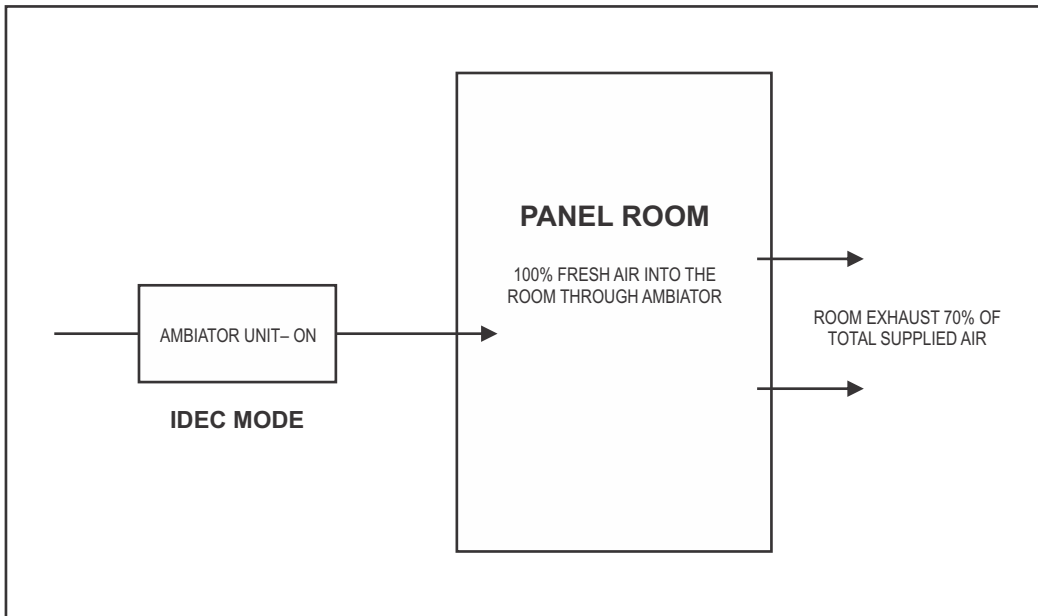

SUMMER OPERATION MODE

Sr. No.	Unit details	Date and time	Ambient	Room
1.	Dornier panel room	15.07.2015	DBT (°C)	DBT (°C)
	HMX-FAAC 35K	01.30 pm	32.00	27.00
		03.30 pm	33.00	28.00
2.	Winding and Instrumentation panel room	15.07.2015	DBT (°C)	DBT (°C)
	HMX-FAAC 7K	01.30 pm	32.00	26.00
		03.30 pm	33.00	27.00

Temperature readings taken during the monsoon season when the unit is running in air-conditioning mode: (90% recirculated air and 10% fresh air)

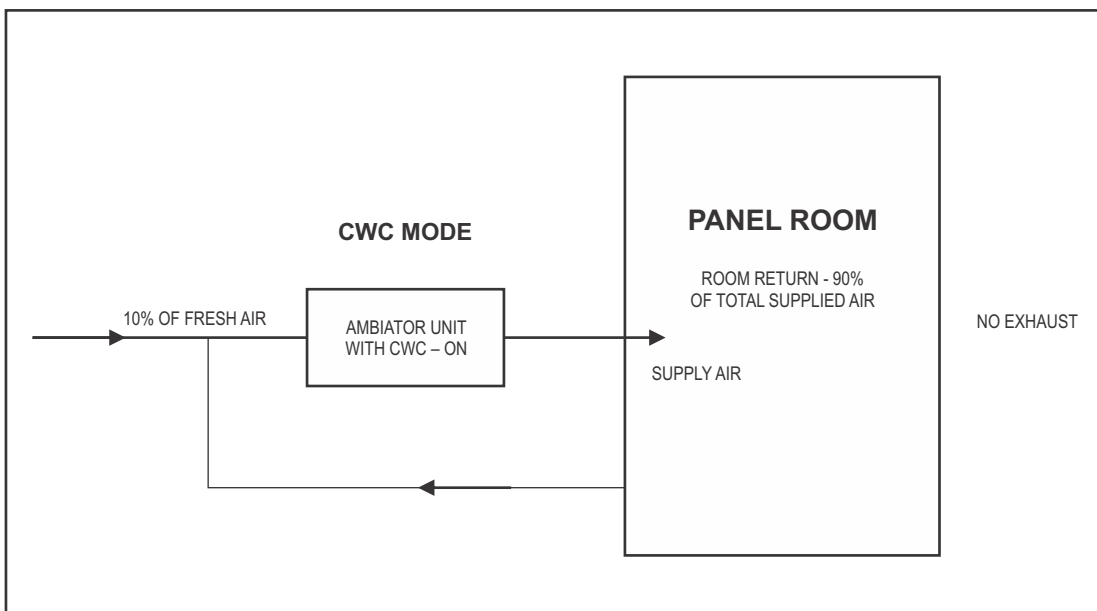

MONSOON OPERATION MODE

The HMX-FAAC has different modes of operation to suit prevailing ambient conditions and can be customised and controlled in a number of ways depending on the process requirement. At JPFL the HMX-FAAC units are switched seamlessly between the following two modes:

- Ambiator mode: indirect + direct evaporative cooling mode
- Air conditioner mode: cooling coil with recirculated air

Result

The HMX-FAAC units consume less than half the energy when running in evaporative cooling mode as compared to a conventional air-conditioning system. To maintain the desired conditions, the units run on fresh air mode for 70% time of the year and on air conditioning mode for rest of the time,. This has lead to a huge amount of energy savings for JPFL plant, and low usage of the cooling coil would also add to the longevity of the system.

Naturally, the management is happy with the performance of the HMX control center solution and is an advocate of this system.

About HMX

HMX, a business unit of A.T.E., designs and manufactures unique, energy-efficient, and eco-friendly products for space and process cooling for the industrial and commercial sectors, using its patented and highly successful DAMA technology. The product range includes stand alone units, fresh air pre-cooling units, and fresh air air-conditioning units. With an installation base of 35 million CFM covering more than 7 million ft² all over India, HMX is making fast strides in providing eco-friendly cooling solutions for people and process comfort.